



INSTALLATION INSTRUCTIONS FOR
PHENOLIC ULTIMATE PRIVACY INSTALLATION

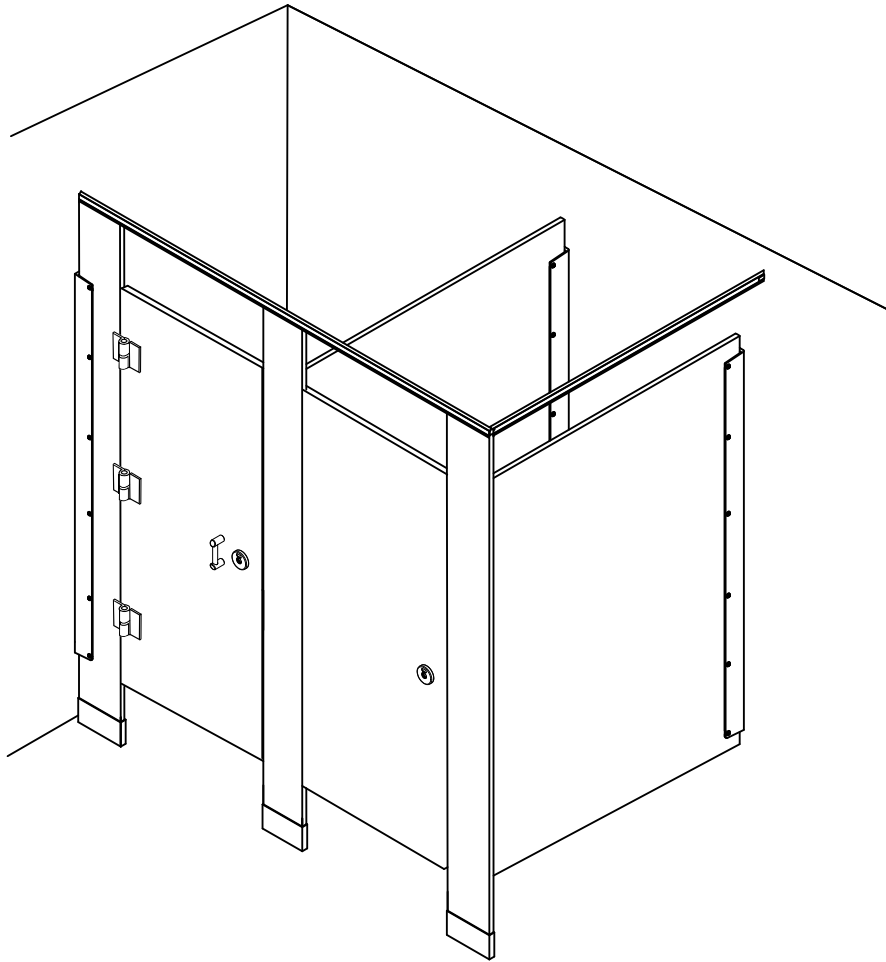

Table of Contents

<u>Floor Anchored/Overhead Braced</u>	<u>Page</u>
Layout, Wall Brackets & Panel Position	3
Pilaster Prep, Pilaster installation & Panel Position	4
Panel to Pilaster/Wall Assembly	5
Pilaster/Wall Assembly	6
Pilaster/Panel Alcove Assembly	7
Head-Rail Assembly	8
Door Hardware In-swing Assembly	9
Door Hardware Out-swing Assembly	10
Latch Assembly.....	11
Hinge Assembly.....	12
Urinal Screen Assembly.....	13
 <u>Product Information</u>	
Care and Maintenance of Toilet Partitions	14

Required Tools

- Power Drill
- T-27 Pin Torx Driver
- Allen Wrench set
- 3/16” Masonry Drill Bit
- 1/4”, #11/64, and #5/32 Drill Bits (and others as needed)
- Drill Bit Stop
- 4’ (or longer) Level
- 6”, 9”, or 12” support as required

Important

The components for this project have been custom fabricated. These components are guaranteed with respect to their manufacture and craftsmanship and were inspected at the factory. Before beginning work, units should be inspected. If damage occurred in transit, report immediately and the freight company or other agencies that may have caused the damage.

STEP 1
LAYOUT
FLOOR ANCHORED/OVERHEAD BRACED

NOTE: FLOOR MUST BE CONCRETE

- A. Review the layout drawings and package lists that have accompanied this job.
- B. Before proceeding, confirm that backing of walls and floor is adequate to support secure mounting of the toilet compartment units.
- C. Establish and mark pilaster center line from back wall.
- D. Establish and mark panel center lines for wall brackets.
- E. Establish pilaster floor fastener locations from side wall according to shop drawings.
- F. Mark wall bracket holes using brackets as template

FIGURE 1

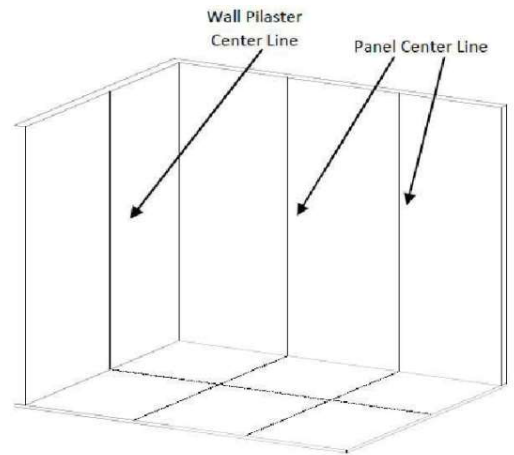

STEP 2
WALL BRACKETS AND FLOOR ANCHORS

- A. Drill holes for wall brackets and floor anchors of appropriate size for particular fastening devices supplied. Typically, 1/4" bit for walls, 1/4" bit for compartment thru-bolts, and 3/16" bit for floors. (Note: as site conditions and hardware combinations vary, and assortment of bit sizes is recommended).
- B. Insert anchoring devices in wall and secure wall brackets.
- C. Attach the shoes to the concrete floor using 1/4" concrete screws. (Note the hole in the side of the shoe should be placed on the inside of the compartment).
- D. Adjust the location of the shoes according to the door opening size, and secure shoes to the floor.

FIGURE 2

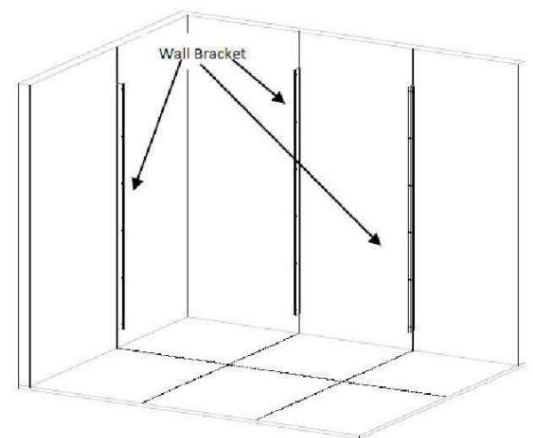

STEP 3
POSITION PANEL

- A. Place panel on the temporary support device.
- B. Set in to wall brackets, but do not fasten panel at this time.

FIGURE 3

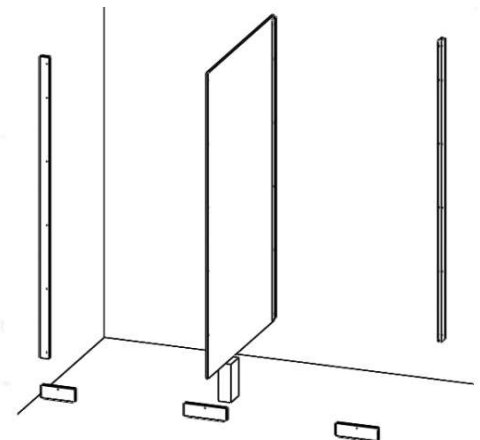
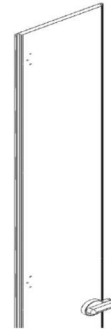

FIGURE 4

STEP 4
PILASTER PREPARATION

- A. Note: that each pilaster is labeled on its front and can be matched to the layout based on that label. Align the U-brackets in position on the rear of the pilasters. Refer to layout drawings and make sure U-brackets are in alignment with wall brackets.
- B. Mark U-bracket holes using the wall brackets as templates. Drill 11/64" diameter x 7/16" deep holes for U-bracket fasteners. (a drill bit are recommended). Correct hole diameter and depth is critical.
- C. Fasten U-brackets to pilaster.



STEP 5
INSTALL PILASTERS

- A. Insert the dowel nut in the side/face of the pilaster where there is a pre-drilled hole.
- B. Insert the leveling bolts and thread in to the dowel nuts.
- C. Insert the pilaster in the shoe.
- D. level the top of all pilasters by adjusting the leveling bolt to the desired positions.

Note: To determine how far to insert the leveling bolt., Find the highest point on the floor, and fully insert the bolt on the pilaster that will be mounted in that location. Adjust all other leveling bolts accordingly.

FIGURE 5

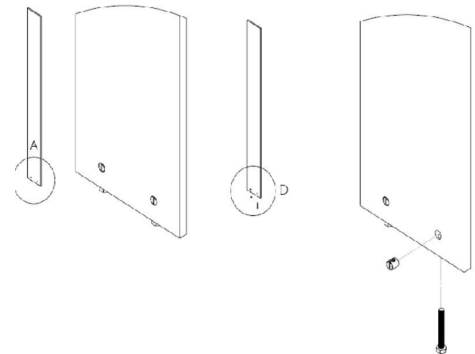

STEP 6
POSITION PANEL

- A. Level the panel and adjust the gaps at either end.
- B. Secure the panel to the wall and pilaster using through-bolts.
- C. Remove panel support device.
- D. Plumb each pilaster and secure with headrail (see page 6 for the headrail detail).
- E. Secure the pilaster to the shoe using shoe screws.

FIGURE 6

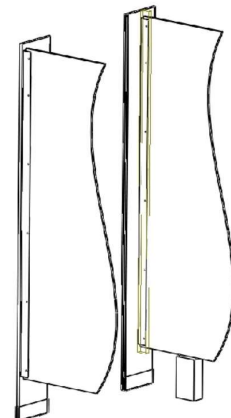

PANEL TO PILASTER/WALL

ASSEMBLY

- A. Plumb panel and fasten panel to wall bracket with through-bolts.
To facilitate the through-bolts, the holes of the panel should be drilled with a 1/4" drill bit through the panel.
- B. Plumb pilaster then fasten the panel to the pilaster bracket using through-bolts and barrel nuts.

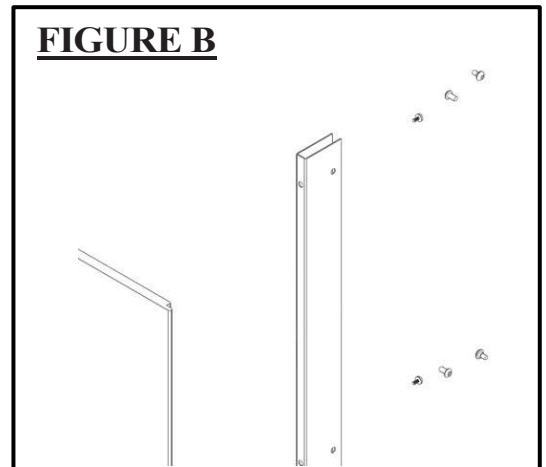
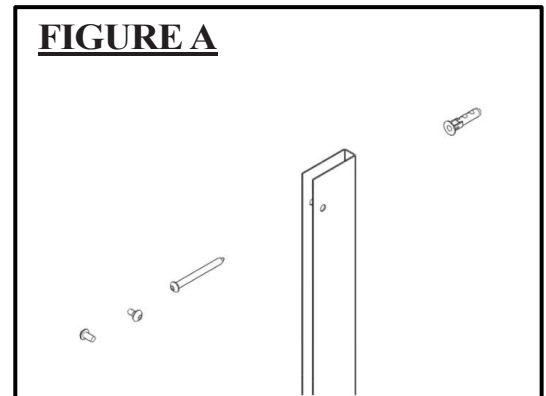
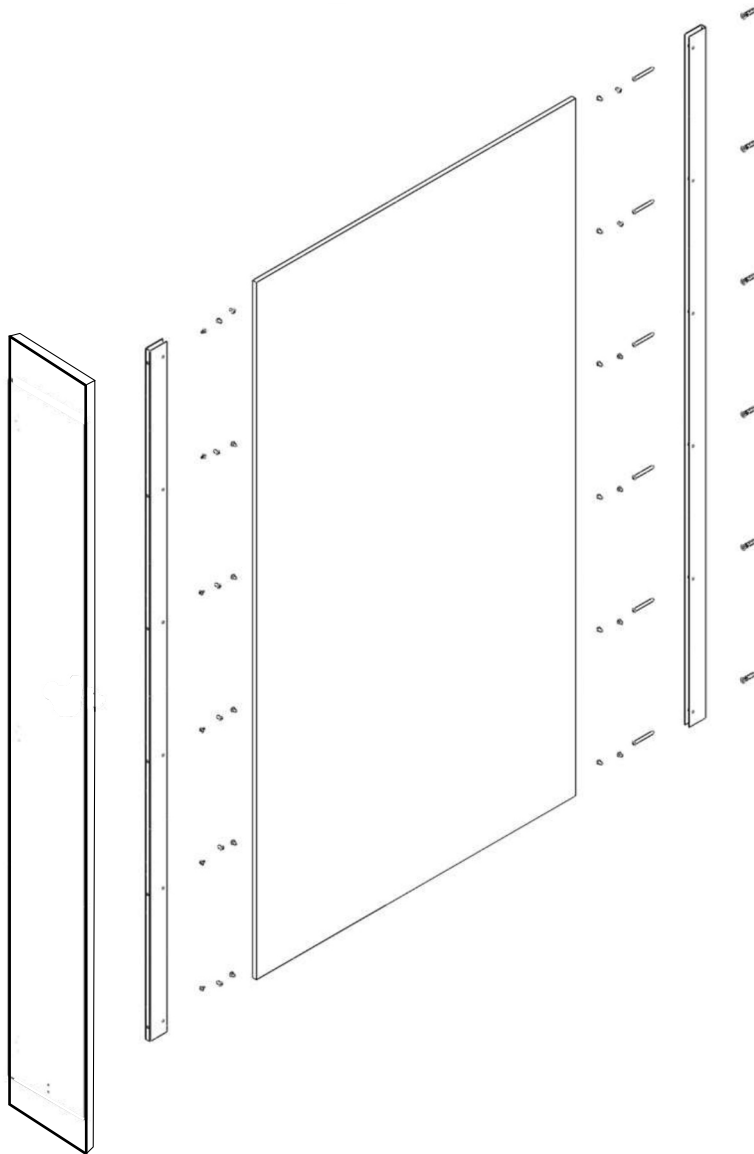

PILASTER/WALL

ASSEMBLY

- A. Plumb panel and fasten panel to wall bracket with through-bolts.
To facilitate the through-bolts, the holes of the panel should be drilled with a 1/4" drill bit through the panel.
- B. Verify that the pilasters are both plumb and level before continuing.
- C. Fasten pilaster to wall bracket using through-bolts.

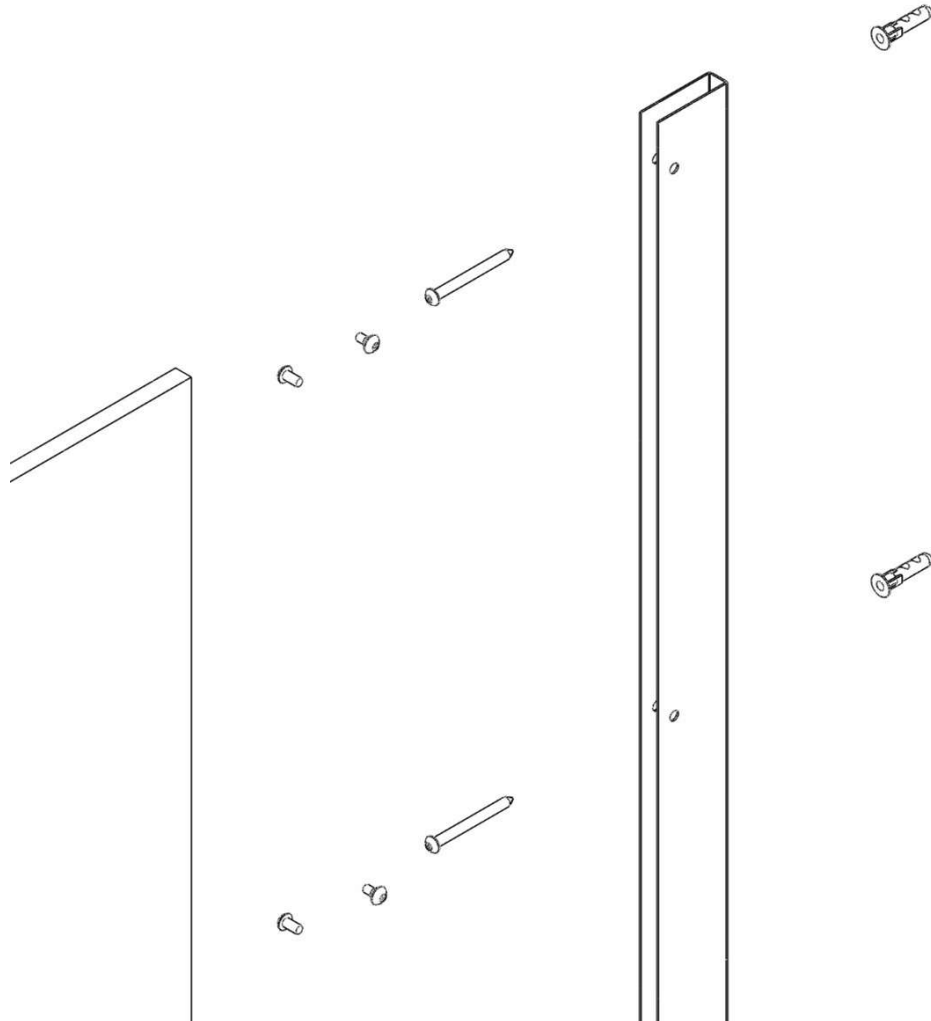

PILASTER/PANEL ALCOVE

ASSEMBLY

- A. For the perpendicular pilaster between two “U” brackets (the tee configuration), first use a through-bolt through the two “U” brackets to fasten the pilaster to the wall panel.
- B. If a standalone alcove is present, the tee configuration is replaced by two alcove brackets (Figure A).
- C. Note: For door details, see pages 7 and 8.

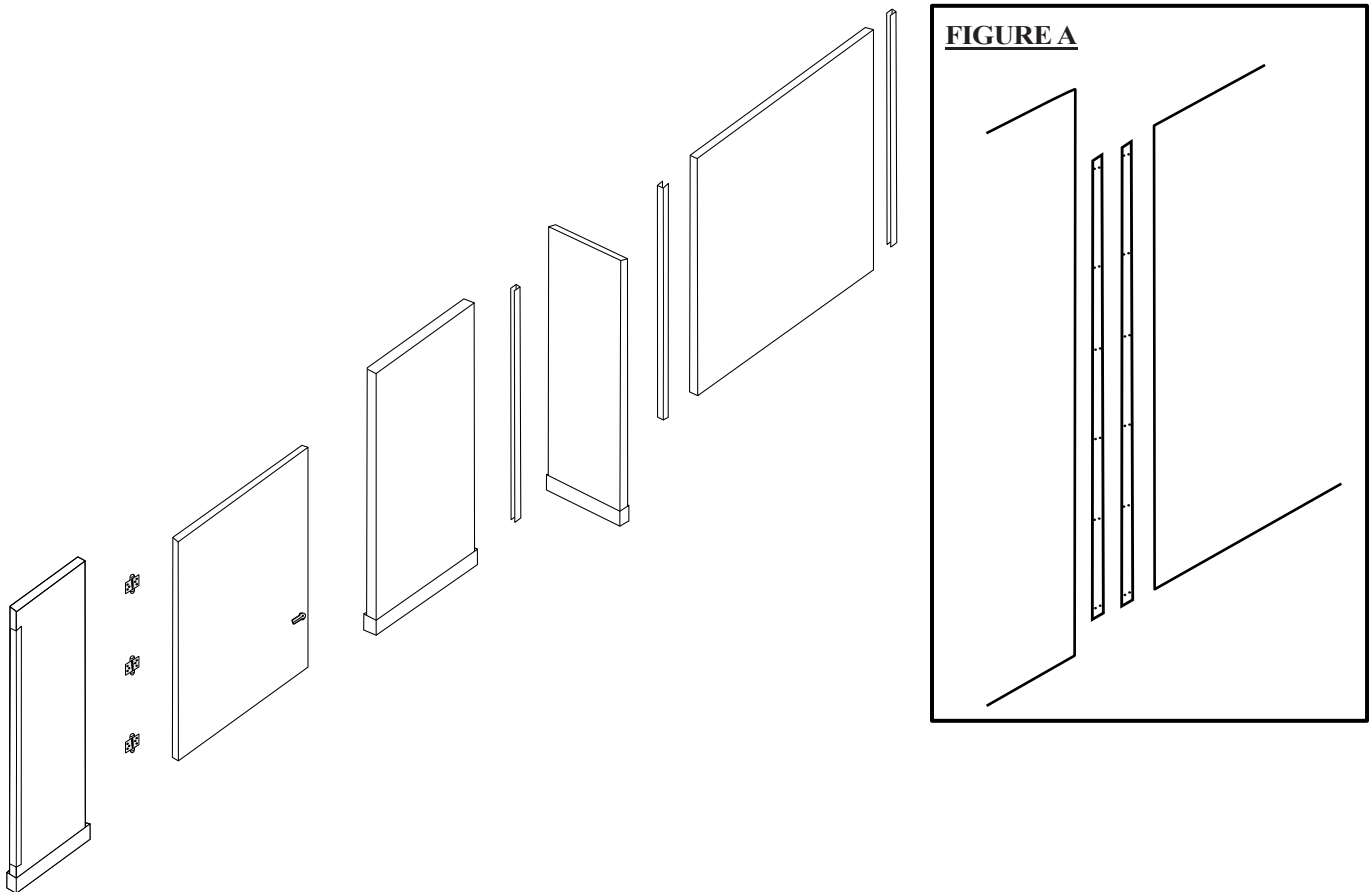

HEADRAIL ASSEMBLY

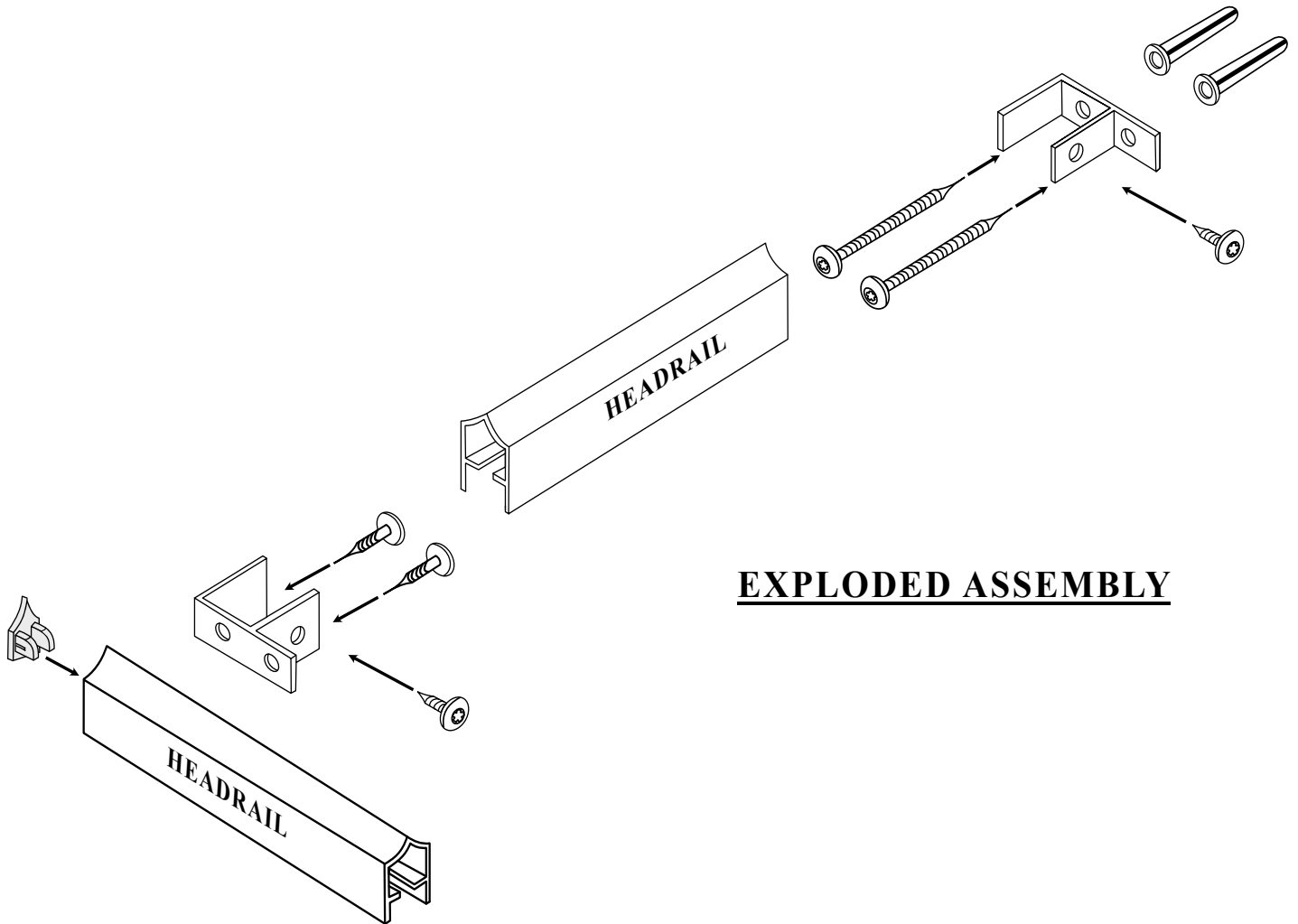

EXPLODED ASSEMBLY

DOOR HARDWARE

INSWING - ASSEMBLY

Note that each Door is labeled and can be matched to the layout based on that label. The hinge and latch holes have been predrilled by the manufacturer. Correct hole diameter and depth is very critical for correct installment.

- A. Place door on temporary support device. Attach the hinges to the pilaster & door using the #10 x 3/4" screws. Remove the support device. (See Pg 10 for the hinge assembly detail.)
- B. Install the latch. (See page 9 for the latch assembly detail.)
- C. Align the keeper with the latch bar near the edge of the pilaster. Using the keeper as a template, mark the hole locations. Using an 11/64" drill bit, drill the keeper holes to a minimum depth of 5/8". Attach the keeper using #10 x 5/8" screws.
- D. Using pliers, gently remove the pin from the end of the coat hook. Remove the escutcheon. Place the coat hook on the door at the desired height. Be sure to verify that the coat hook will strike the panel/wall before the corner of the door. Mark the holes, then using an 11/64" drill bit, drill to a minimum depth of 7/16". Attach the coat hook to the door using the #10 x 1/2" screws. Reinstall the escutcheon and snap it tightly against the door. Reinsert the pin to the top end of the coat hook.
- E. Using the door pull as a template, mark the holes, then using an 11/64" drill bit, drill to a minimum depth of 7/16". Attach the door pull to the door using the #10 x 5/8" screws.

Note that coat hooks and door pulls for ADA doors must be installed no higher than 48" above the finished floor. See Pg 8 for pass through door pull installation instructions.

KEEPER ASSEMBLY

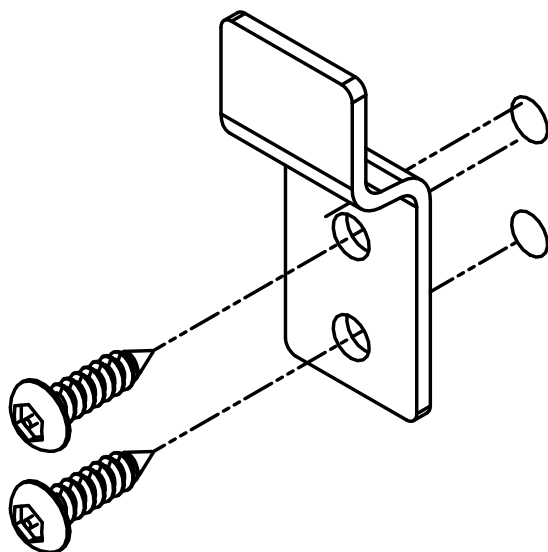

**KEEPER
ASSEMBLY**

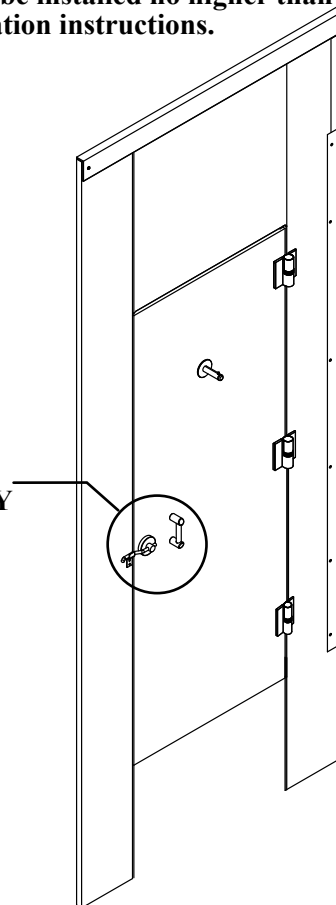

DOOR HARDWARE OUTSWING - ASSEMBLY

**Note that each Door is labeled and can be matched to the layout based on that label.
The hinge and latch holes have been predrilled by the manufacturer.
Correct hole diameter and depth is very critical for correct installment.**

- A. Place door on temporary support device. Attach the hinges to the pilaster & door using the #10 x 3/4" screws. Remove the support device. (See Pg 10 for the hinge assembly detail.)
- B. Install the latch. (See page 9 for the latch assembly detail.)
Note that the keeper is not required for outswing doors.
- C. Using pliers, gently remove the pin from the end of the coat hook. Remove the escutcheon. Place the coat hook on the door at the desired height. Be sure to verify that the coat hook will strike the panel/wall before the corner of the door. Mark the holes, then using an 11/64" drill bit, drill to a minimum depth of 7/16". Attach the coat hook to the door using the #10 x 1/2" screws. Reinstall the escutcheon and snap it tightly against the door. Reinsert the pin to the top end of the coat hook.
- D. Repeat step C if installing an additional coat hook as an outswing bumper.
- E. Using the door pull as a template, mark the holes, then using an 1/4" drill bit, drill through the door. Attach the door pull to the door using 1-1/2" bolts.

Note that coat hooks and door pulls for ADA doors must be installed no higher than 48" above the finished floor.

LATCH ASSEMBLY

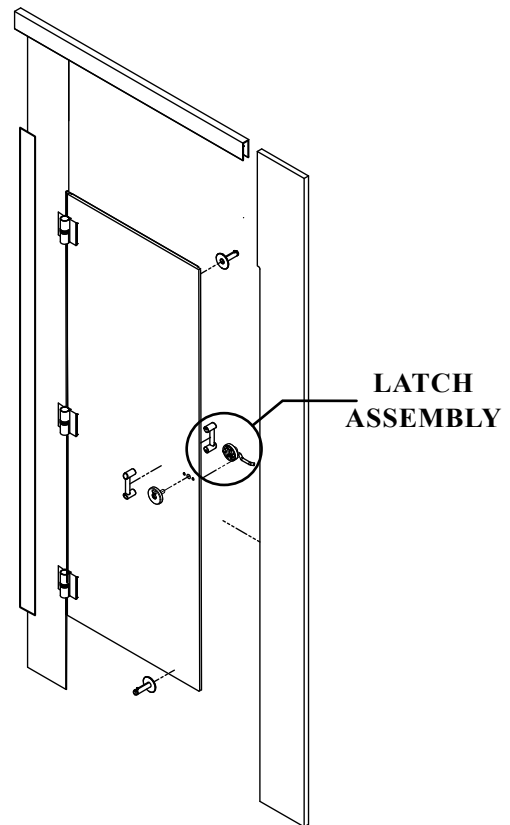
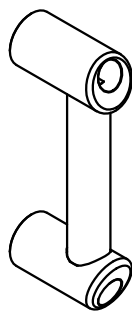
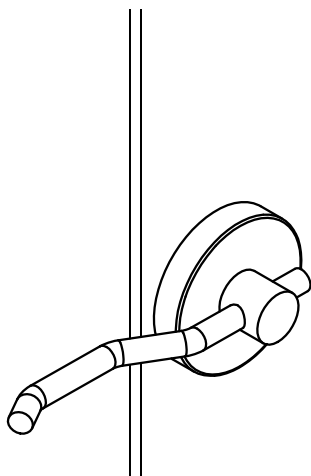

INDICATOR LATCH ASSEMBLY

Press the latch handle and the indicator dial placement sleeve into the predrilled holes in the door. Insert the M5 x 25mm bolts through the door and tighten. Turn the handle to the latched position. With the red portion on top, press the center shaft of the indicator dial into the latch. Align the indicator cover and press together on each side of the door until you hear a click.

INDICATOR COVER
WITH INSERT

INDICATOR DIAL
&
CENTER SHAFT

M5 X 25MM
BOLTS

INDICATOR DIAL
PLACEMENT SLEEVE

LATCH HANDLE

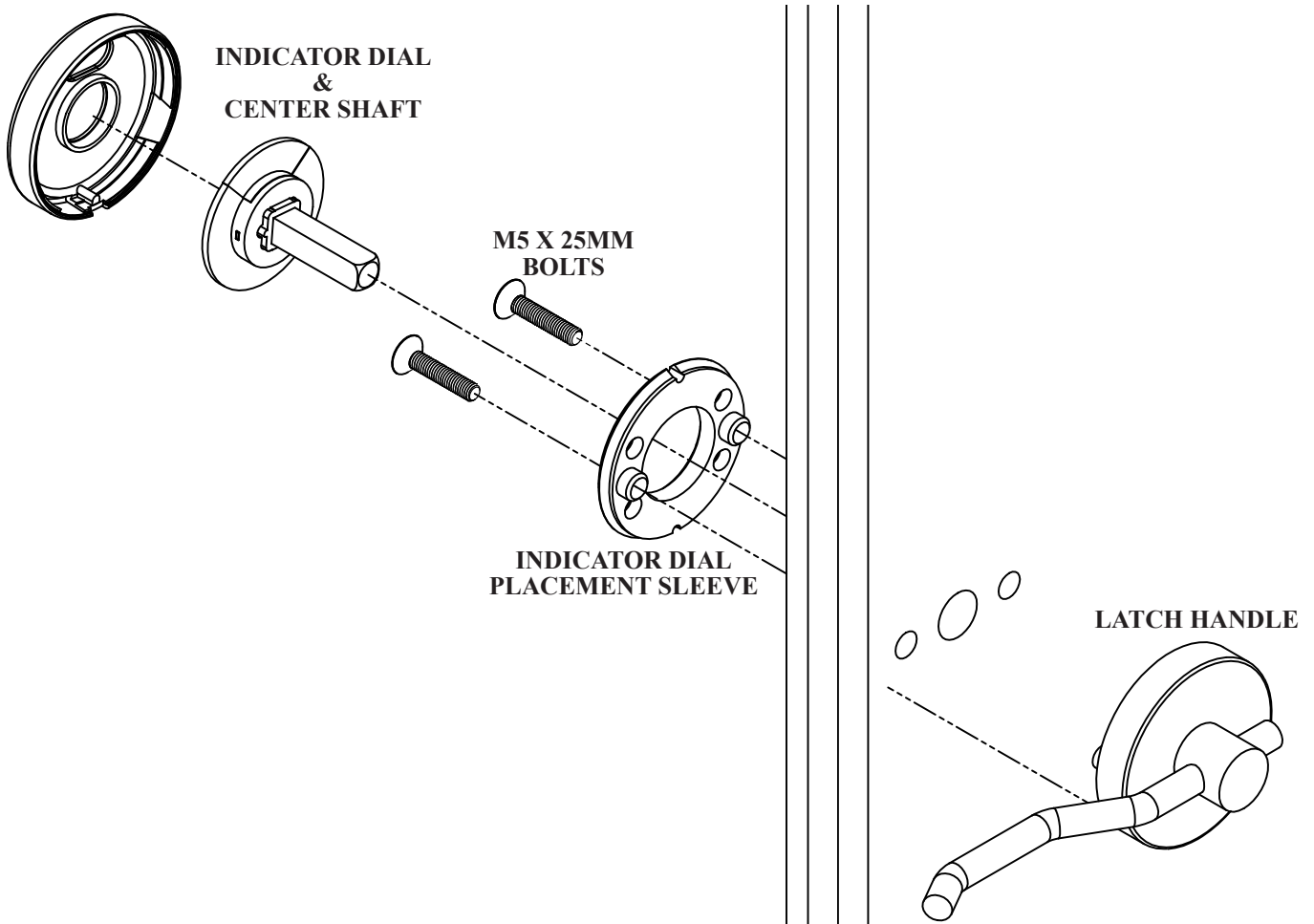

HINGE ASSEMBLY

Align hinges with the predrilled holes in the pilaster and door.

Attach using #10 x 3/4" screws.

Slide the cover plate on from the outside edge.

Tighten set screw with a 3/32" Hex wrench.

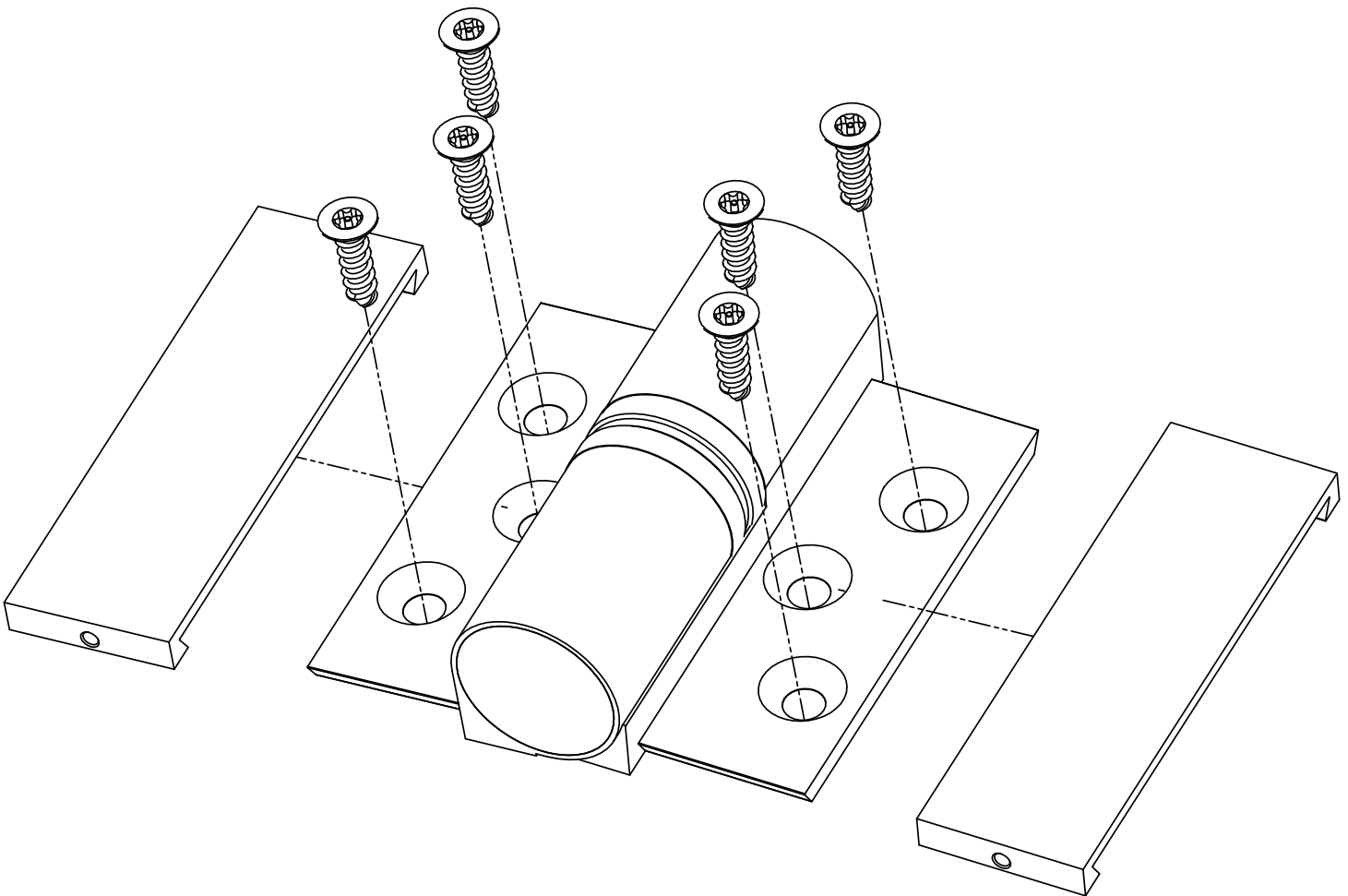

URINAL SCREEN

ASSEMBLY

- A. Before proceeding, confirm that the backing of the wall is adequate to support the mounting of urinal screens. Check shop drawings for layout.
- B. Using bracket as a template. Mark and drill 1/4" holes.
- C. Insert plastic shields into the walls and secure wall brackets with 2 1/2" wall screws.
- D. Place urinal screen on a support device at desired height.
- E. Drill 1/4" holes through the urinal screen and fasten with through-bolts.

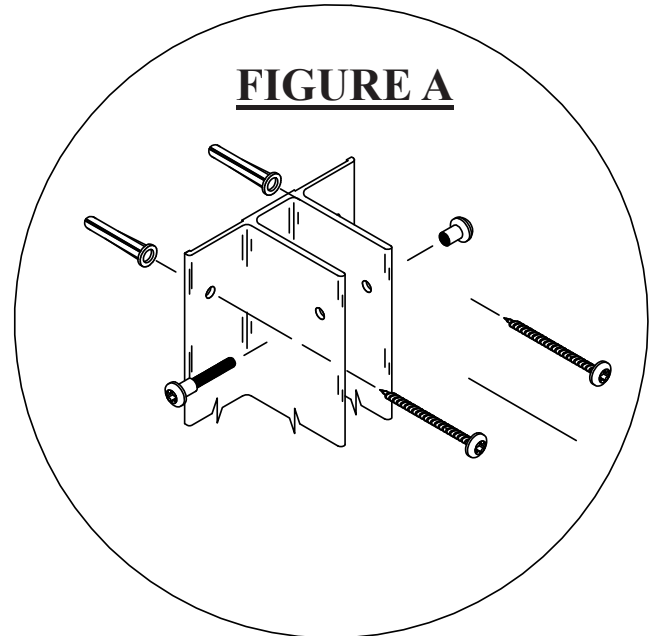
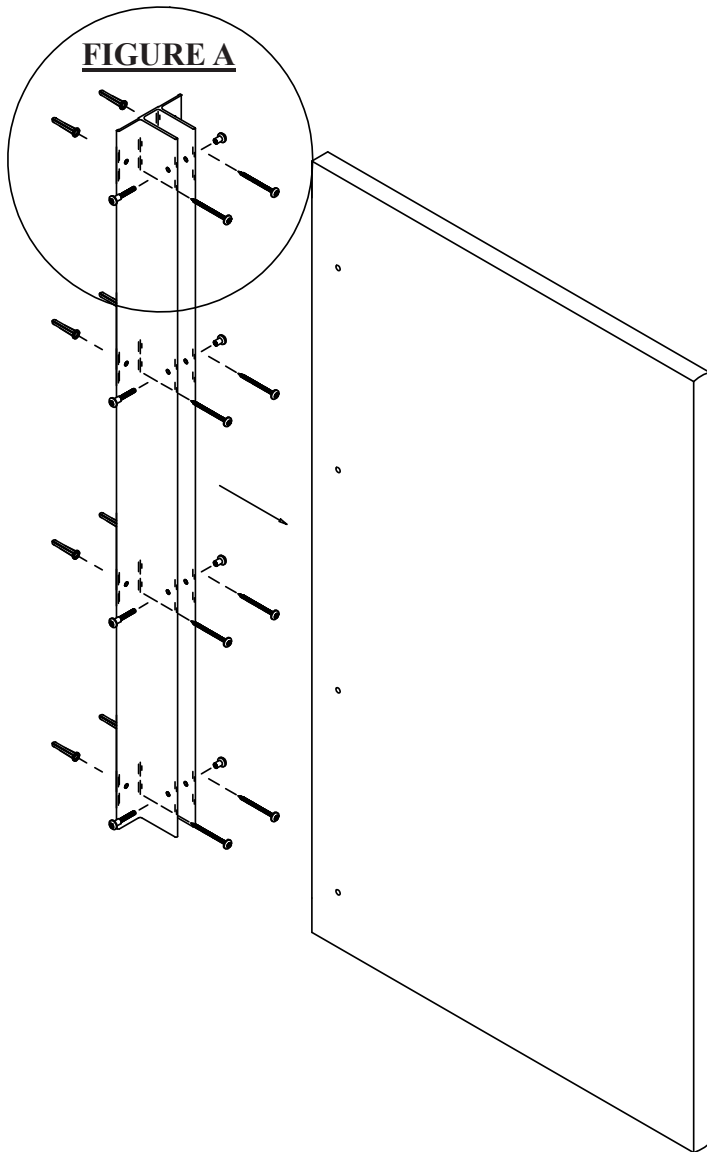

Product Information

CARE AND MAINTENANCE OF **BATHROOM PARTITIONS**

In order to provide bathroom partitions with proper care and maintenance, the following instructions must be followed:

- A. All surfaces must be kept clean with water and a mild soap solution only.
- B. In areas of high humidity, the rooms must be properly ventilated.
- C. “Hosing down” or wet-washing of these units may cause water adsorption and damage.
- D. For maximum protection, periodic application of any standard furniture wax will be beneficial.

WARNING

Under no circumstances should these components be subjected to:

- Abrasive powders or pads
- Bathroom cleaners
- Ceramic tile cleaners
- Solutions containing more than 1% by volume of ammonia
- Solutions containing acids or lye
- Solutions containing enzymes

Attention to work progress during new construction or renovation is paramount. Some cleaning services may use agents for ceramics and tiles that will damage these components.