



INSTALLATION INSTRUCTIONS FOR
ALPACO ELEGANCE PARTITIONS

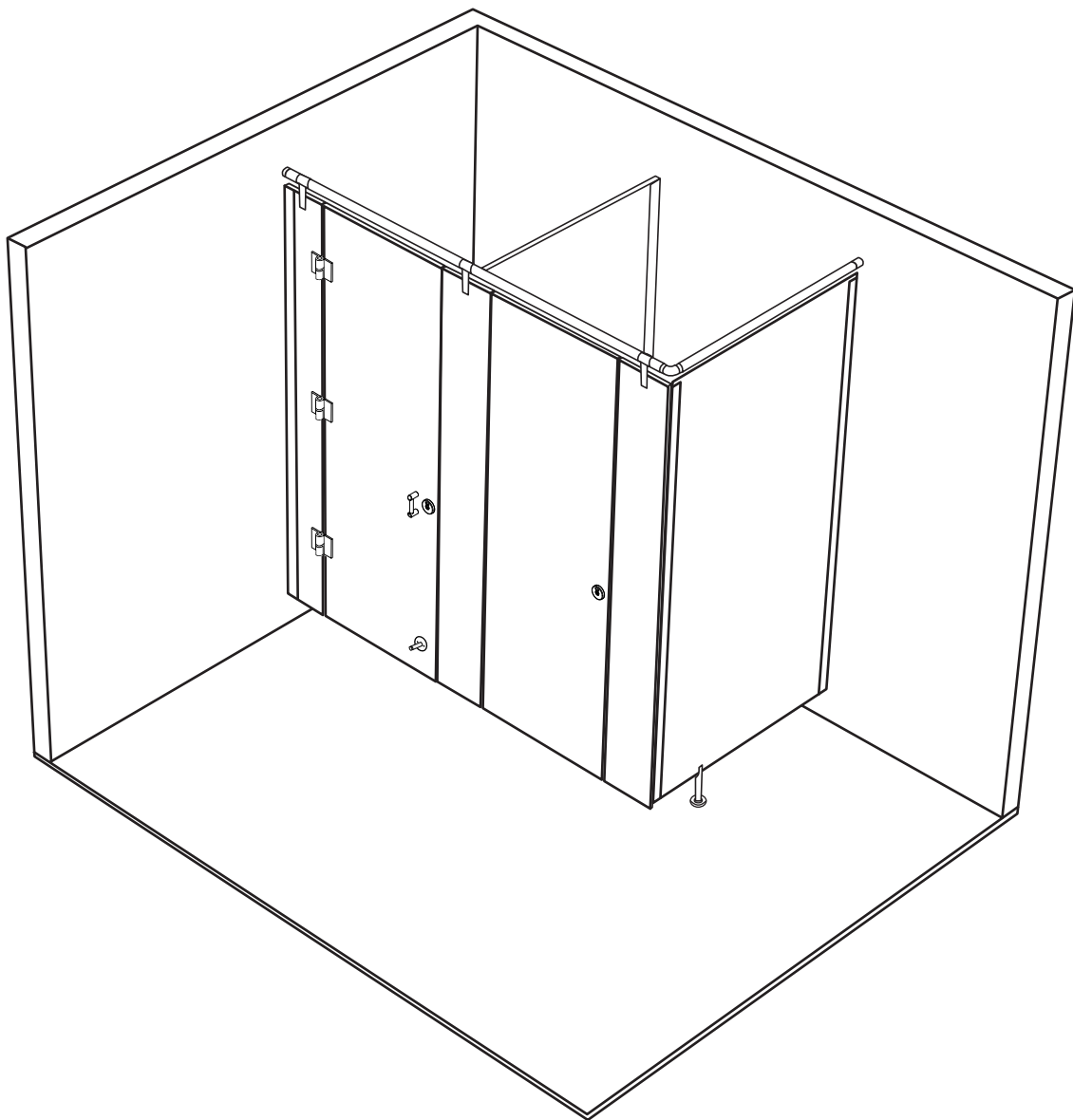

Table of Contents

<i>Alpaco OverHead Braced</i>	<u>Page</u>
Step 1,2,	3
Step 3,4	4
Step 5,6	5
Panel to Pilaster/Wall Assembly	6
Pilaster/Wall Assembly	7
Pilaster/Panel Alcove Assembly	8
Tongue And Groove Stacked Panel Detail	9
Head Rail Connection Details	10
Head Rail Clips Details	11
Door Hardware Inswing Assembly	12
Door Hardware Outswing Assembly	13
Weather Stripping Installation	14
Indicator Latch Assembly	15
Hinge Assembly	16
Urinal Screen Assembly	17
Care and Maintenance of Bathroom Partitions	18

Required Tools

- Power Drill
- T-27 Pin Torx Driver
- Allen Wrench set
- 5/16" Masonry Drill Bit
- 1/4", #11/64, and #5/32 Drill Bits
(and others as needed)
- Drill Bit Stop
- 4' (or longer) Level
- 6", 9", or 12" support as required

Important

The components for this project have been custom fabricated. These components are guaranteed with respect to their manufacture and craftsmanship and were inspected at the factory.

Before beginning work, units should be inspected. If damage occurred in transit, report immediately and the freight company or other agencies that may have caused the damage.

STEP 1:

LAYOUT

- A. Before proceeding, confirm that the backings of the walls and floor are adequate to support the secure mounting of the ALPACO Classic units.
- B. Review the layout drawings and package lists that have accompanied this order.
- C. Establish and mark panel center lines for wall brackets. See the accompanied fabrication drawings for compartment dimensions.
- D. Mark wall bracket holes using the brackets as templates. Depending on the pedestal height the bottom of the bracket should sit at 4 1/4", 6 1/4" or 9 1/4" above the floor.
- E. If installing an alcove, please see page 8 for details.

FIGURE 1

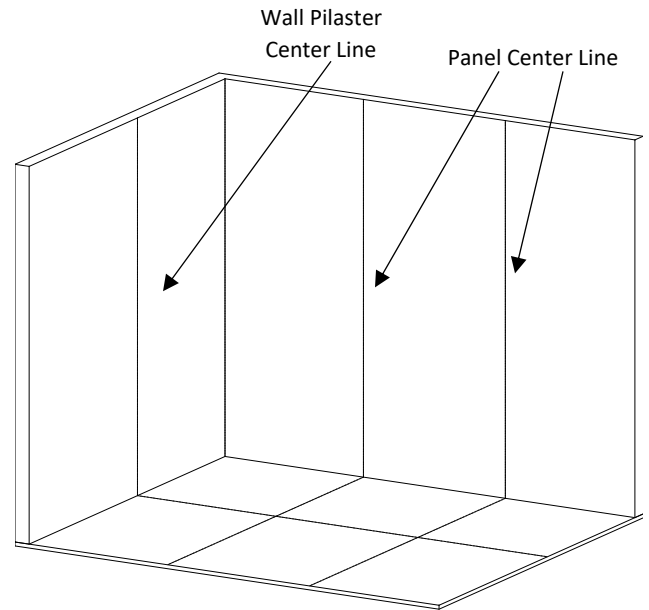

STEP 2:

WALL BRACKETS

- A. Drill 1/4" diameter x 2.5" deep holes for the red plastic shields provided using a 1/4" drill bit. However, as site conditions vary, an assortment of bit sizes is recommended.
- B. Insert the anchoring devices into the walls, and secure the wall brackets.

FIGURE 2

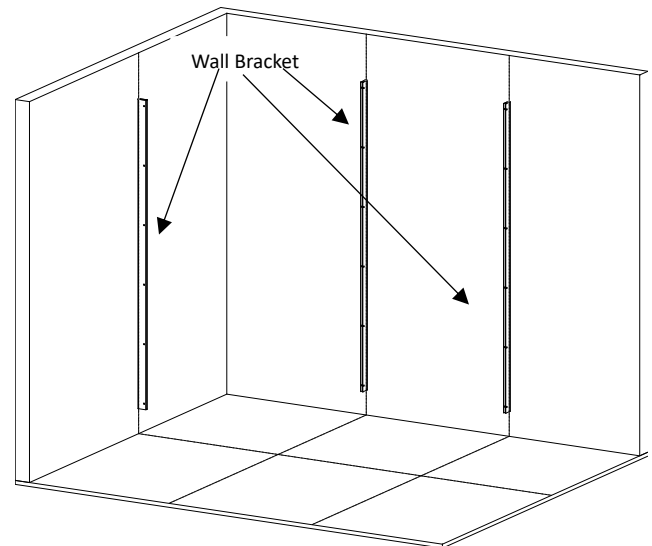

STEP 3:

POSITION PANEL

- A. Assemble pedestal and adjust it to the desired height by turning clockwise or counterclockwise.
- B. Place the panel on a temporary support device. Set the panel into the wall bracket and unanchored pedestal.
- C. Adjust the gap between the panel and wall bracket.
- D. Plumb, level, and fasten the panel to the wall bracket.
- E. Remove the support device and ensure panels are level across the stalls.

FIGURE 3

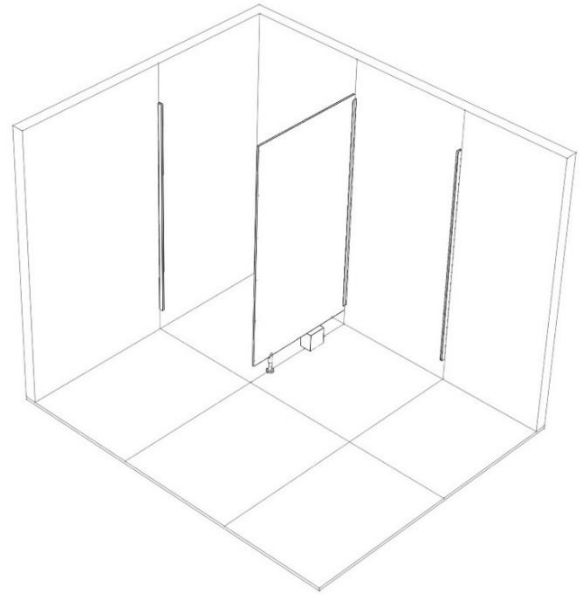

STEP 4:

PILASTER PREPARATION

- A. **Note that each pilaster is labeled on its front and can be matched to the layout based on that label.** Align the U-brackets in position on rear of pilasters. Refer to layout drawings and make sure U-brackets are in alignment with wall brackets.
- B. Mark U-bracket holes using the wall brackets as templates. Drill 11/64" diameter x 7/16" deep holes for U-bracket fasteners (a #11/64" drill bit and drill bit stop are recommended). **Correct hole diameter and depth is critical.**

Note: Reference pages 5, 6 & 7 as needed for the next 3 steps.

FIGURE 4

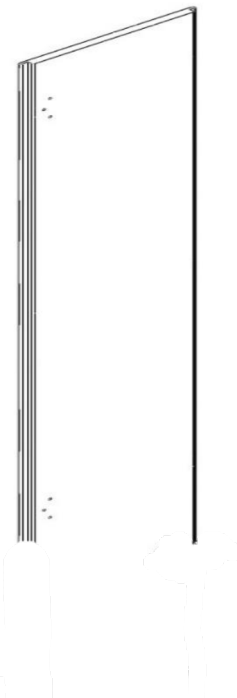

STEP 5: SECURING PILASTERS AND PEDESTALS

- A. A temporary support device is highly recommended to place under each pilaster to assist in alignment.
- B. Plumb each pilaster and fasten the pilaster to the panel with U-brackets using through-bolts through the panel.
- C. Establish door openings as measured from the inner edge of one pilaster to the inner edge of the other pilaster.
- D. Mark holes on the floor for the pedestals. Drill floor and panel for each pedestal using a 5/16" masonry drill bit. Attach each pedestal to the floor and the panel.
- E. Remove the support device.

FIGURE 5

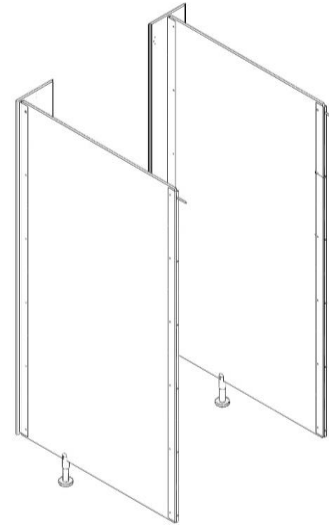

STEP 6: HEAD RAIL

- A. Plumb each pilaster.
- B. Verify door openings between pilasters prior to drilling holes in head rail. Holes for head rail clip and couplers are predrilled at the factory.
Head Rail must be cut to size.
- C. Attach the head rail (see figure 6 for head rail connections). **Tube should be seated fully into the connectors and drilled to accept fasteners using a #5/32" drill bit.**

FIGURE 6

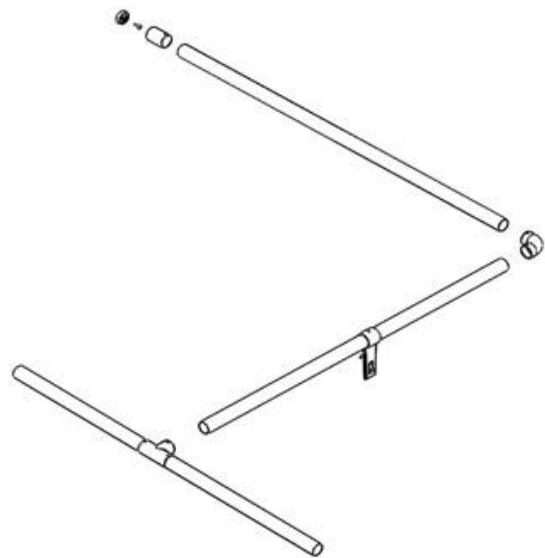

See page 10 & 11 for detailed illustrations of the head rail components.

PANEL TO PILASTER/WALL ASSEMBLY

- A. Plumb panel and fasten panel to wall bracket with through-bolts.
To facilitate the through-bolts, the holes of the panel should be drilled with a 1/4" drill bit through the panel.
- B. Plumb pilaster then fasten the panel to the pilaster bracket using through-bolts and barrel nuts.

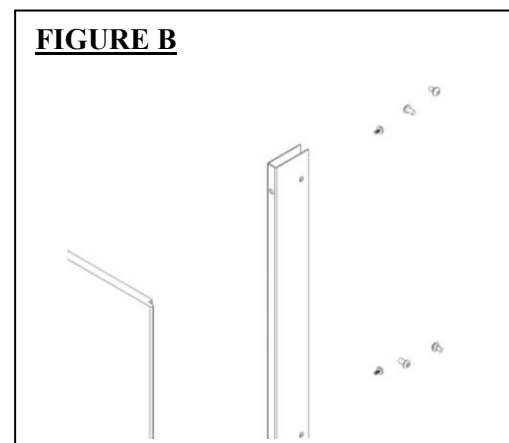
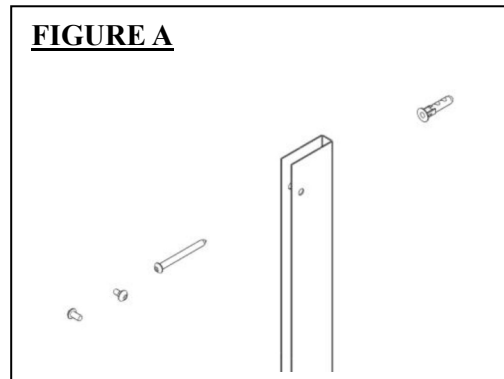
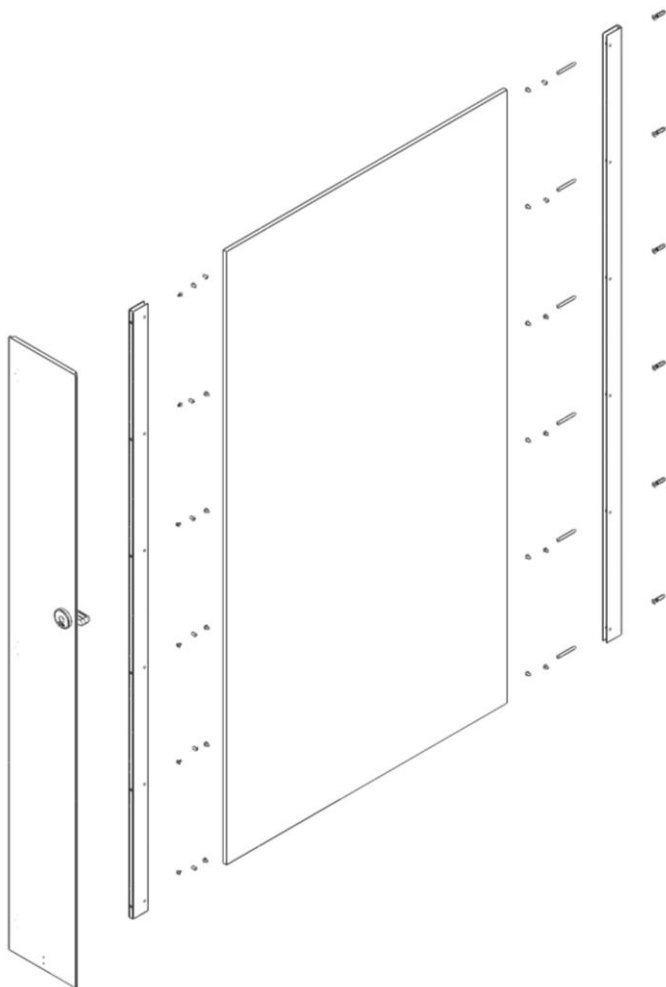

PILASTER/WALL
ASSEMBLY

- A. Verify that the pilasters are both plumb and level before continuing.
- B. Fasten the pilaster to the wall bracket using through-bolts and barrel nuts.

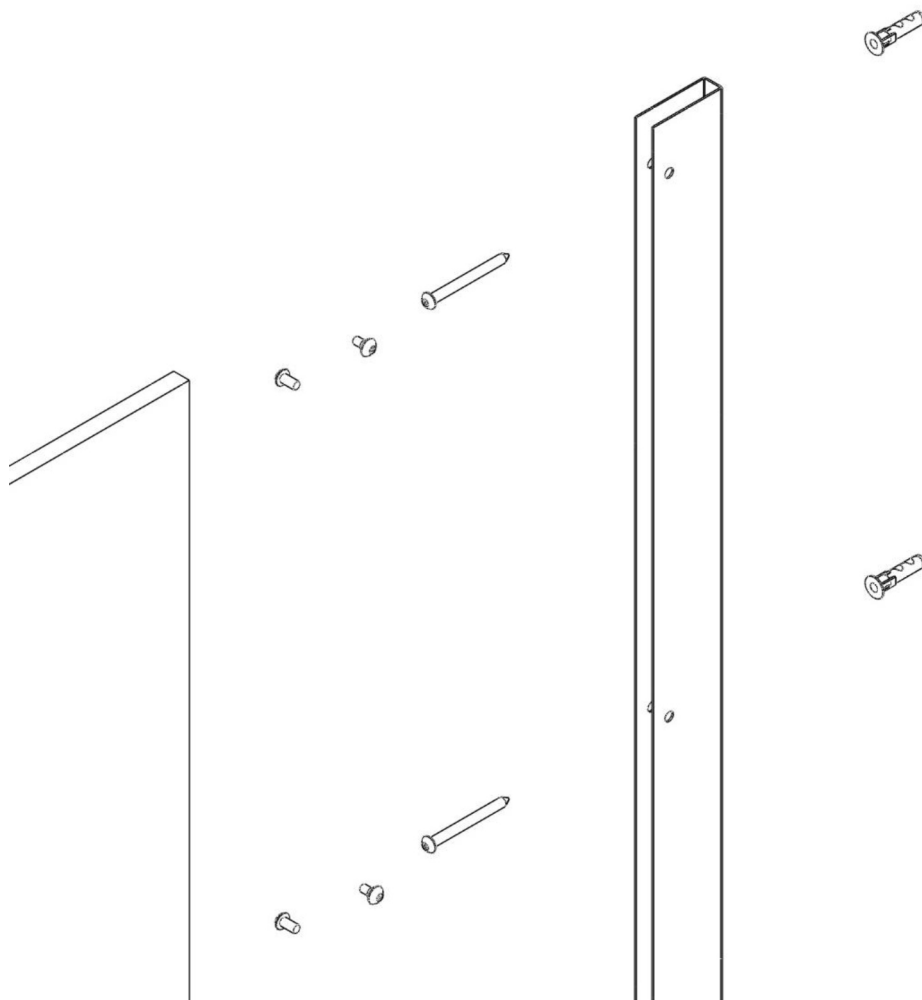

PILASTER/ PANEL ALCOVE

ASSEMBLY

- A. For the perpendicular pilaster between two “U” brackets (the tee configuration), first use a through-bolt through the two “U” brackets to fasten the pilaster to the wall panel.
- B. If a standalone alcove is present, the tee configuration is replaced by two alcove brackets (Figure A).

Note: For door details, see pages 12 and 13.

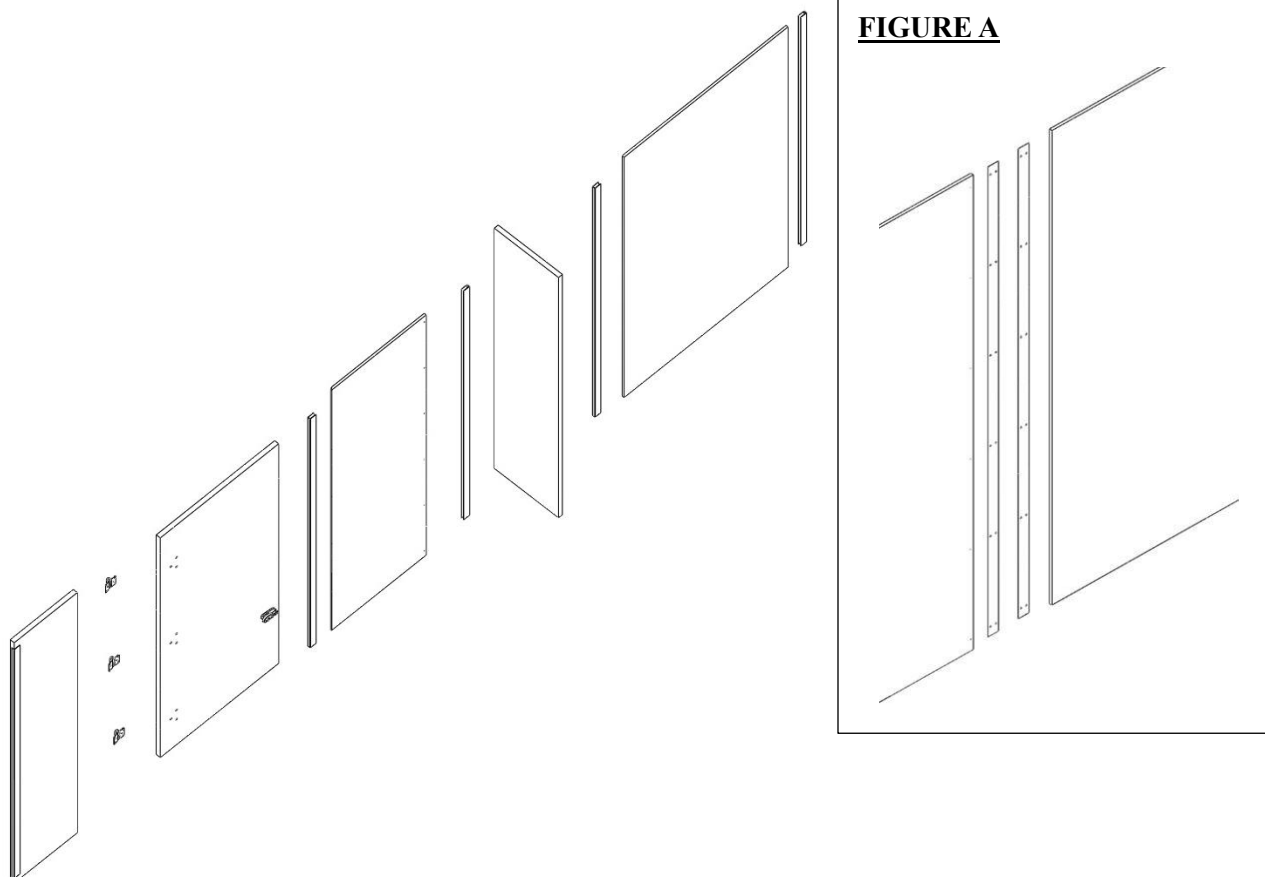

TOUNGE & GROVE
STACKED PANEL
DETAIL

- A. Place top panel on top of the bottom panel aligning the tongue & groove edges and slide into the bracket.
- B. Align the front edges of the top and bottom panel.

Note: The top of all panels should be level with one another throughout the room.

FIGURE A

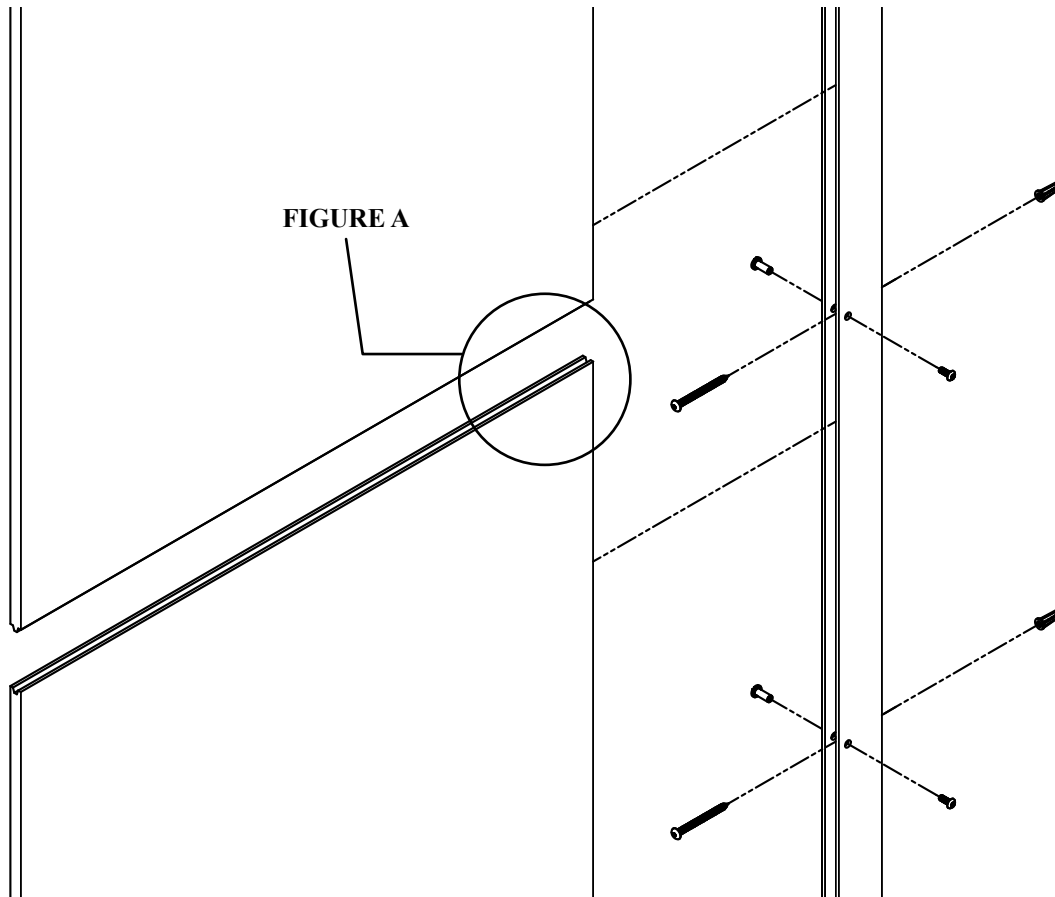
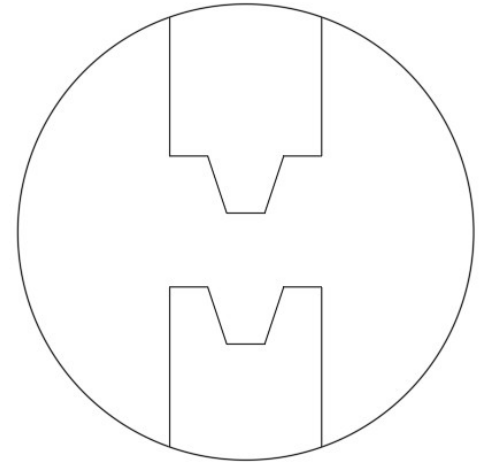

HEAD RAIL CONNECTIONS

**HEAD RAIL
TO WALL
CONNECTION**

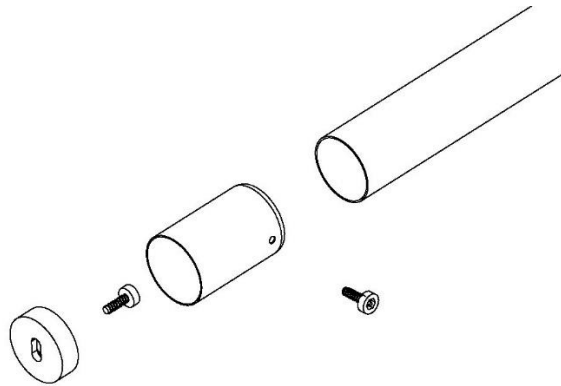

**HEAD RAIL
“T” CONNECTION**

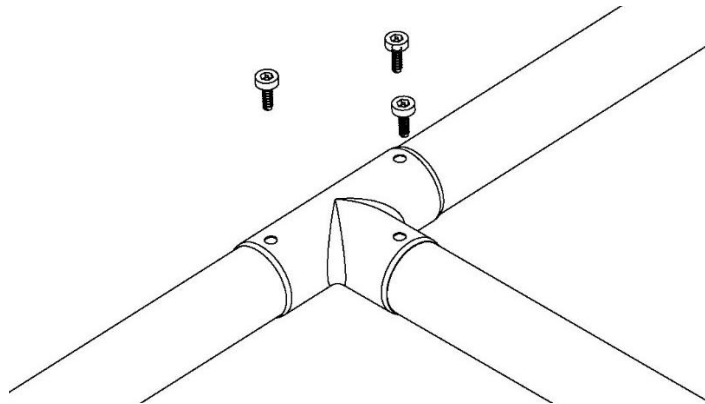

**HEAD RAIL
“L” CONNECTION**

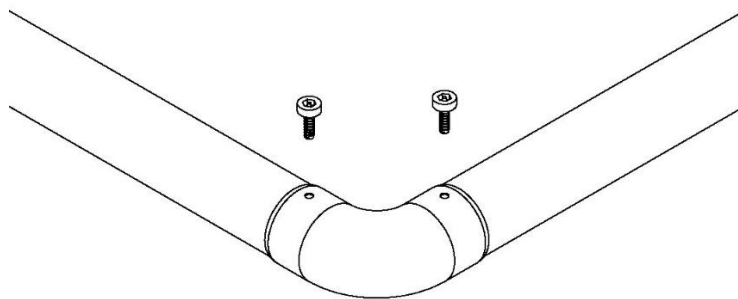

HEAD RAIL CLIPS

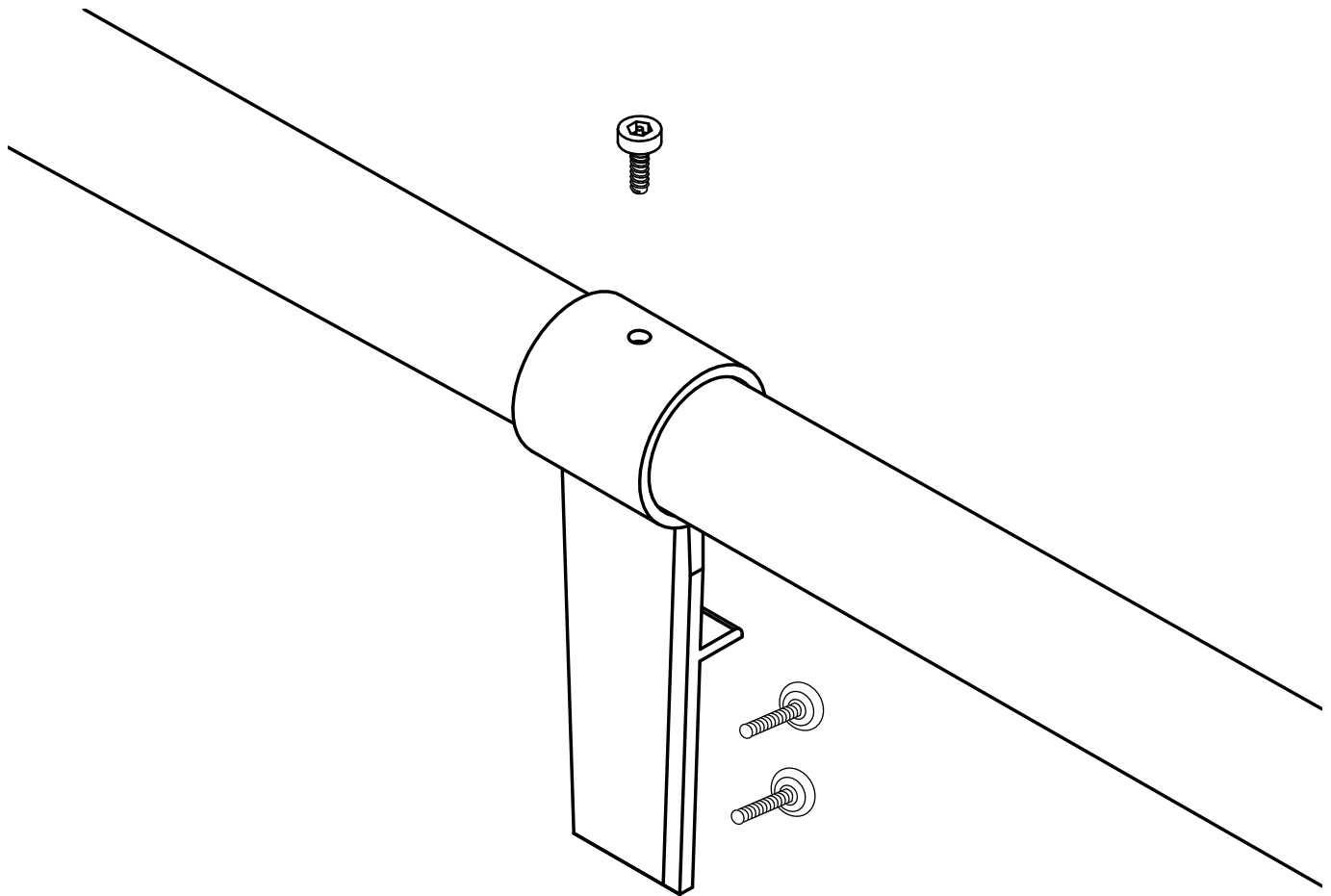

10" or smaller pilaster get one headrail clip.
12" or larger pilster get two headrail clips.

Mount the clip as close to the edge of the pilaster as possible.

Allow space for the headrail fittings.

Use the template provided in the kit for correct placement to drill holes.
Predrill with 1/4" drill bit then finish with 3/8" drill bit.

Insert bolts and slowly fasten to the pilaster.

Note: Pilasters 8" and smaller require one bracket.
Pilasters 12" and larger require two bracekts.
10" "A" style pilasters require one bracket.
10" "T" & "Z" require two bracekts.

DOOR HARDWARE

INSWING - ASSEMBLY

Note that each Door is labeled and can be matched to the layout based on that label. The hinge and latch holes have been predrilled by the manufacturer. Correct hole diameter and depth is very critical for correct installment.

- A. Place door on temporary support device. Attach the hinges to the pilaster & door using the #10 x 3/4" screws. Remove the support device. (See Pg 15 for the hinge assembly detail.)
- B. Install the latch. (See page 14 for the latch assembly detail.)
- C. Align the keeper with the latch bar near the edge of the pilaster. Using the keeper as a template, mark the hole locations. Using an 11/64" drill bit, drill the keeper holes to a minimum depth of 5/8". Attach the keeper using #10 x 5/8" screws.
- D. Using pliers, gently remove the pin from the end of the coat hook. Remove the escutcheon. Place the coat hook on the door at the desired height. Be sure to verify that the coat hook will strike the panel/wall before the corner of the door. Mark the holes, then using an 11/64" drill bit, drill to a minimum depth of 7/16". Attach the coat hook to the door using the #10 x 1/2" screws. Reinstall the escutcheon and snap it tightly against the door. Reinsert the pin to the top end of the coat hook.
- E. Using the door pull as a template, mark the holes, then using an 11/64" drill bit, drill to a minimum depth of 7/16". Attach the door pull to the door using the #10 x 5/8" screws.

Note that coat hooks and door pulls for ADA doors must be installed no higher than 48" above the finished floor. See Pg 13 for pass through door pull installation instructions.

KEEPER ASSEMBLY

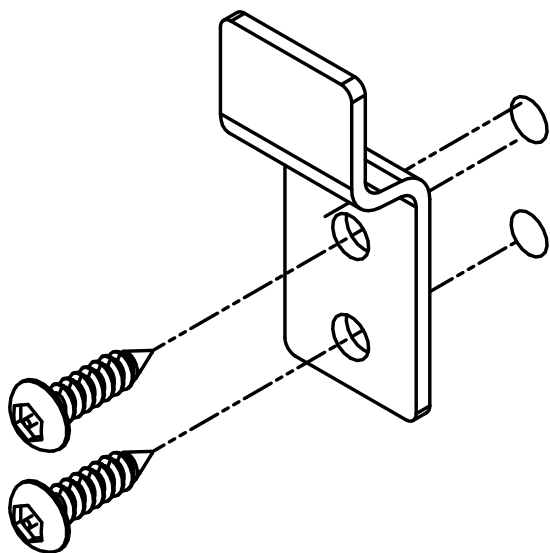

KEEPER ASSEMBLY

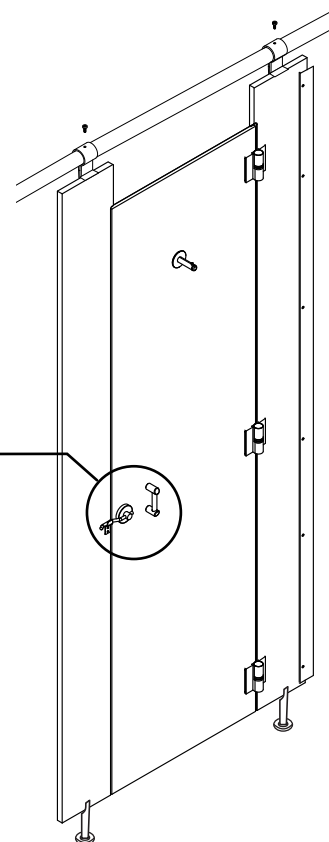

DOOR HARDWARE ASSEMBLY - OUTSWING

Note that each Door is labeled and can be matched to the layout based on that label.

The hinge and latch holes have been predrilled by the manufacturer.

Correct hole diameter and depth is very critical for correct installment.

A. Place door on temporary support device. Attach the hinges to the pilaster & door using the #10 x 3/4" screws. Remove the support device. (See Pg 15 for the hinge assembly detail.)

B. Install the latch. (See page 14 for the latch assembly detail.)

Note that the keeper is not required for outswing doors.

C. Using pliers, gently remove the pin from the end of the coat hook. Remove the escutcheon. Place the coat hook on the door at the desired height. Be sure to verify that the coat hook will strike the panel/wall before the corner of the door. Mark the holes, then using an 11/64" drill bit, drill to a minimum depth of 7/16". Attach the coat hook to the door using the #10 x 1/2" screws. Reinstall the escutcheon and snap it tightly against the door. Reinsert the pin to the top end of the coat hook.

D. Repeat step C if installing an additional coat hook as an outswing bumper.

E. Using the door pull as a template, mark the holes, then using an 1/4" drill bit, drill through the door. Attach the door pull to the door using 1-1/2" bolts.

Note that coat hooks and door pulls for ADA doors must be installed no higher than 48" above the finished floor.

LATCH ASSEMBLY

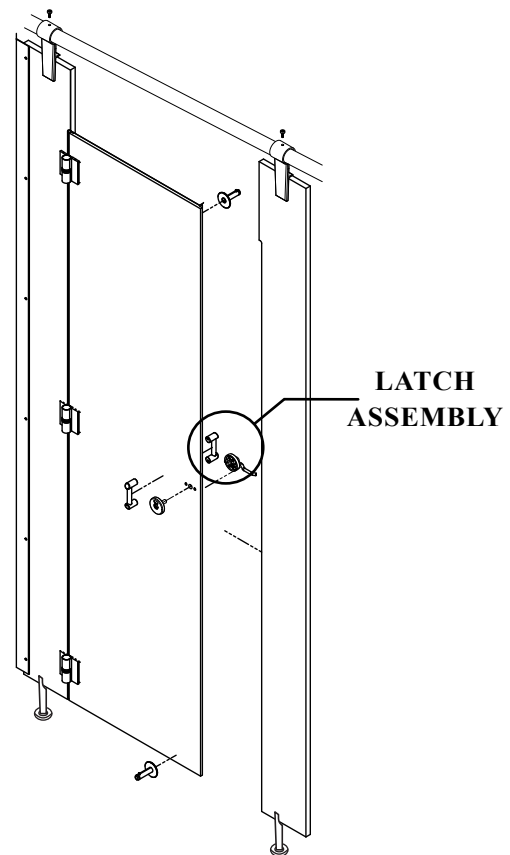
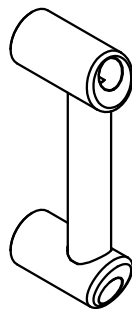
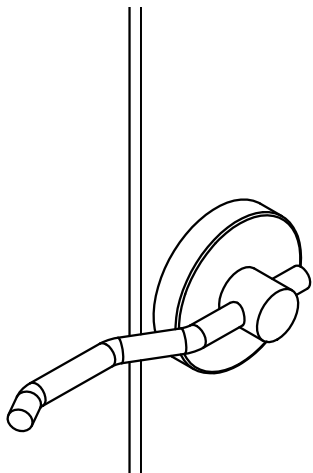

DOOR HARDWARE

WEATHER STRIPPING INSTALLATION

**NOTE: To help lessen the impact of the door.
Correct length must be cut in field.**

- A. Measure the routed portion of the door.
Cut weather strip to the appropriate length depending upon the door size.
- B. Remove the protective layer from the back of the weather strip.
Install the weather strip on the door by pressing firmly to attach correctly.

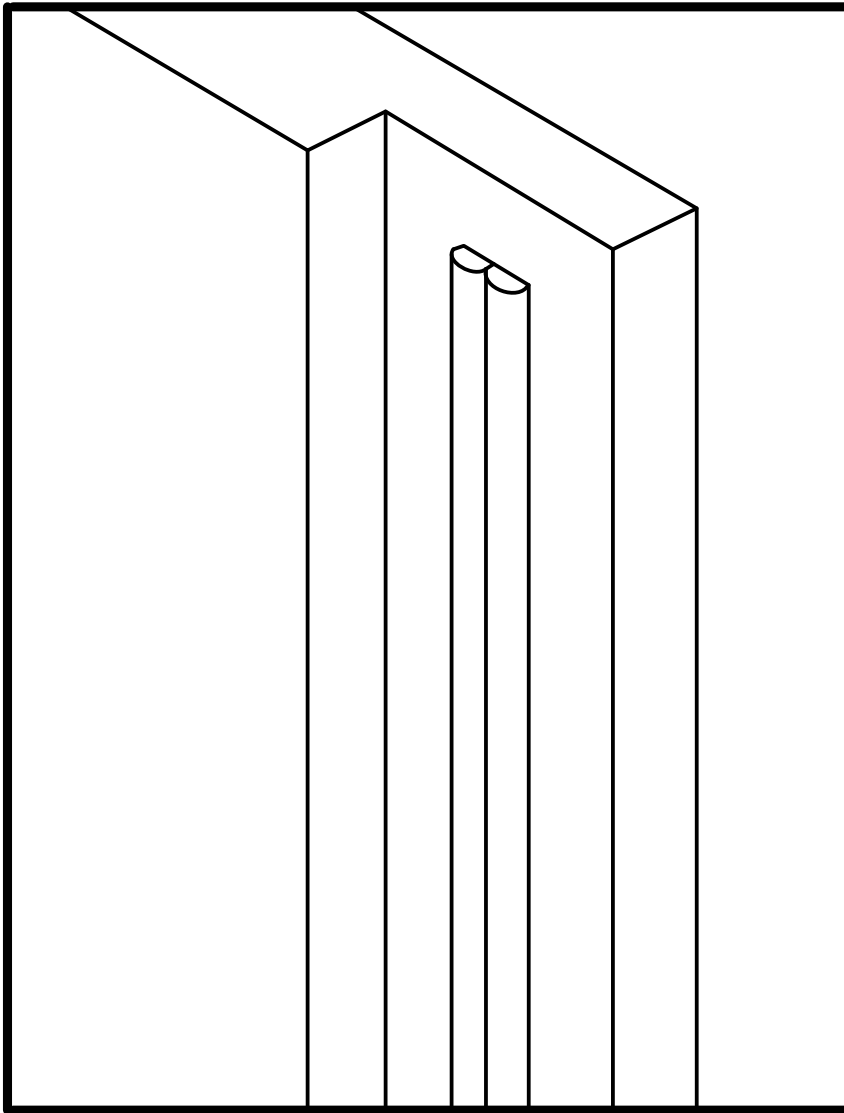

INDICATOR LATCH ASSEMBLY

Press the latch handle and the indicator dial placement sleeve into the predrilled holes in the door. Insert the M5 x 25mm bolts through the door and tighten. Turn the handle to the latched position. With the red portion on top, press the center shaft of the indicator dial into the latch. Align the indicator cover and press together on each side of the door until you hear a click.

INDICATOR COVER WITH INSERT

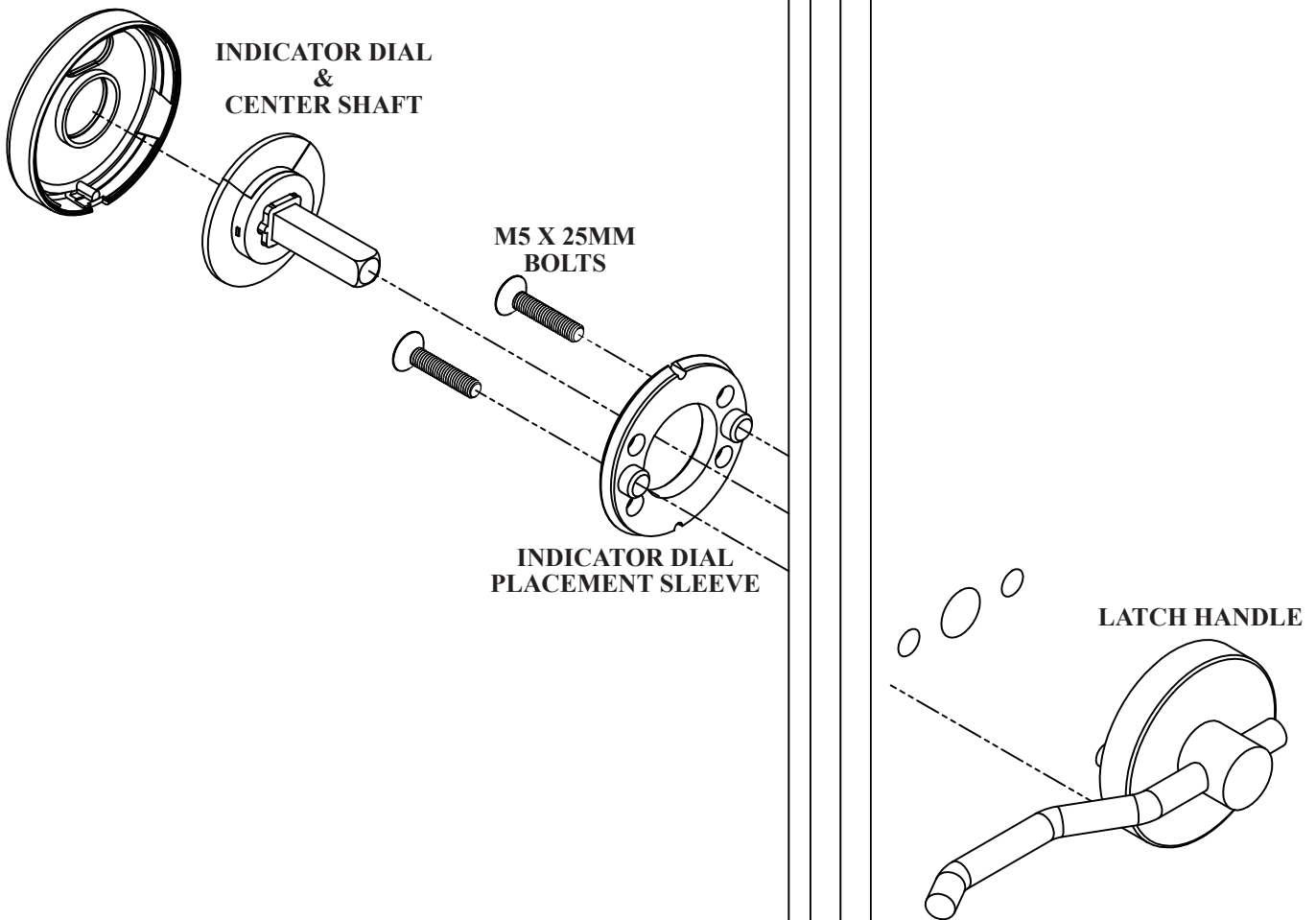

HINGE ASSEMBLY

Align hinges with the predrilled holes in the pilaster and door.

Attach using #10 x 3/4" screws.

Slide the cover plate on from the outside edge.

Tighten set screw with a 3/32" Hex wrench.

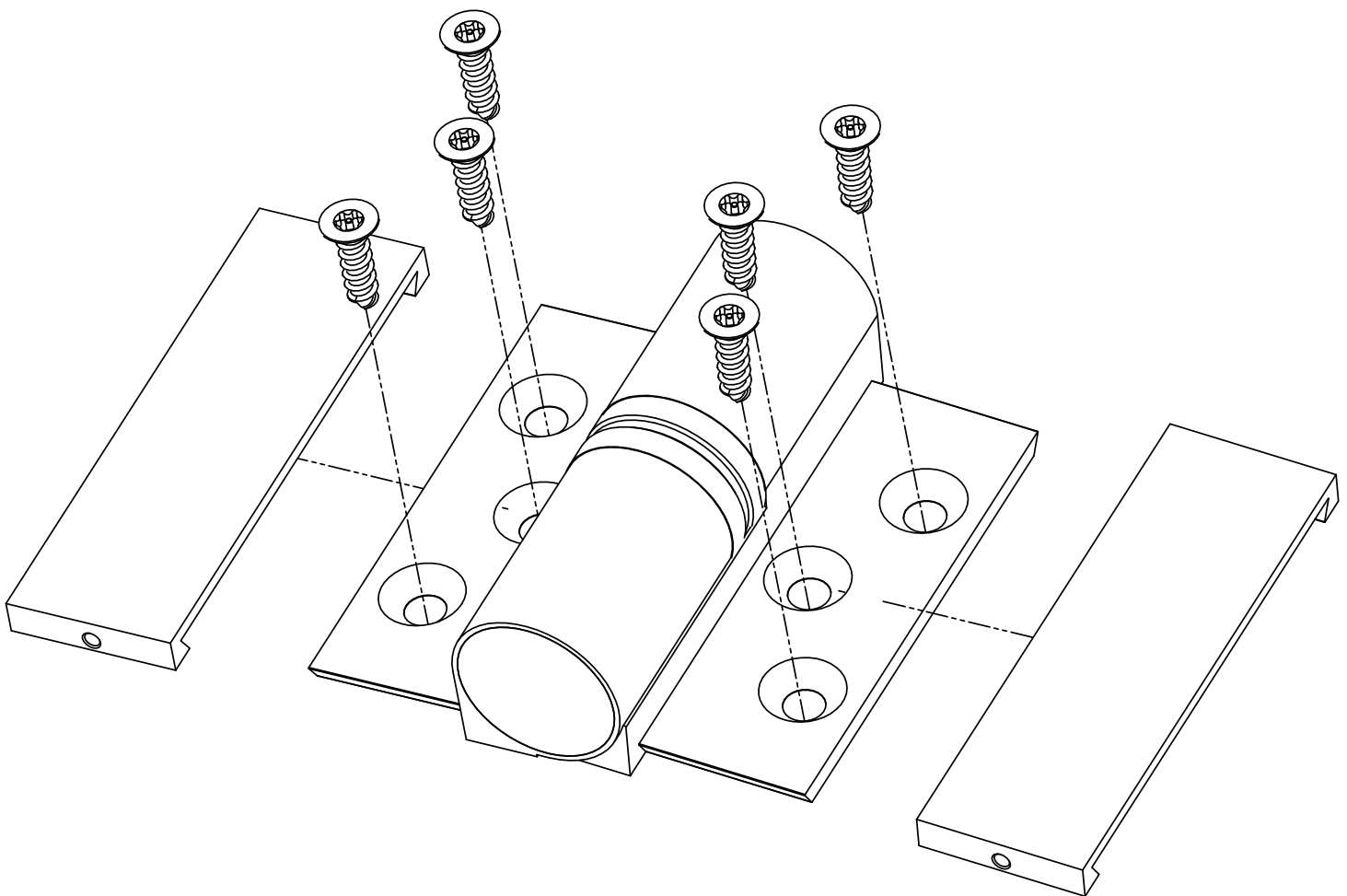

URINAL SCREEN**ASSEMBLY**

- A. Before proceeding, confirm that the backing of the screens.
Check shop drawings for layout.
- B. Insert plastic shields into the walls and secure wall brackets with
2.5" wall screws.
- C. Place urinal screen on a support device at desired height.
- D. Drill holes through the urinal screen to facilitate through-bolts.
Set the urinal screen into wall brackets and fasten.

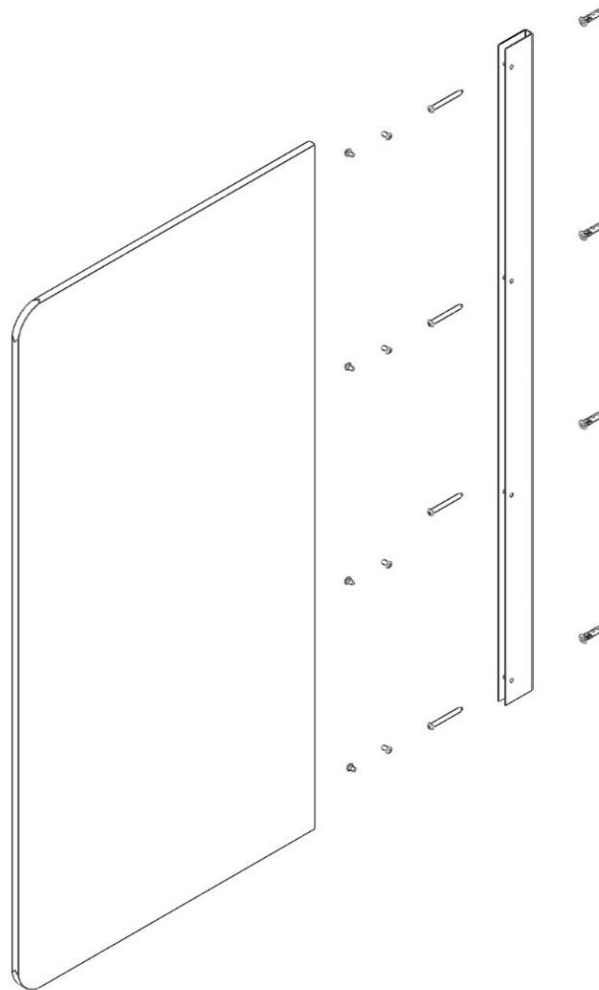

CARE AND MAINTENANCE OF BATHROOM PARTITIONS

In order to provide bathroom partitions with proper care and maintenance, the following instructions must be followed:

- A. All surfaces must be kept clean with water and a mild soap solution only.
- B. In areas of high humidity, the rooms must be properly ventilated.
- C. “Hosing down” or wet-washing of these units may cause water adsorption and damage.
- D. For maximum protection, periodic application of any standard furniture wax will be beneficial.

WARNING

Under no circumstances should these components be subjected to:

- Abrasive powders or pads
- Bathroom cleaners
- Ceramic tile cleaners
- Solutions containing more than 1% by volume of ammonia
- Solutions containing acids or lye
- Solutions containing enzymes

Attention to work progress during new construction or renovation is paramount.

Some cleaning services may use agents for ceramics and tiles that will damage these components.